



Developing profitable customers



**THE NEW ORKEL DENS-X COMPACTOR  
BALING WITH HIGH DENSITY  
AND HIGH QUALITY**



## **HISTORY OF QUALITY**

**WE ARE PROUD TO BE THE FIRST COMPANY IN THE WORLD TO PUT SMALL PARTICLES INTO BALES. WE ARE THEREFORE THE MOST EXPERIENCED MANUFACTURER OF THESE MACHINES, FOR WHICH WE EARNED AN INTERNATIONAL INNOVATION PRIZE, «NEUHEIT INNOVATION», AT AGRITECHNICA.**



# **PROFITABLE MACHINERY MADE OF NEW IDEAS AND SOLID CRAFTSMANSHIP**

*Orkel is an innovative market leader in the development of new products. Our team of highly skilled engineering professionals are working relentlessly to create cutting edge agricultural and industrial machinery and to improve our existing product range.*

*With the new Orkel Dens-X Compactor we are proud to present a compactor of outstanding capacity, durability and user friendliness, enabling our customers to meet the challenges of the future.*

**LEIF HAUGUM**

*Head of Development*

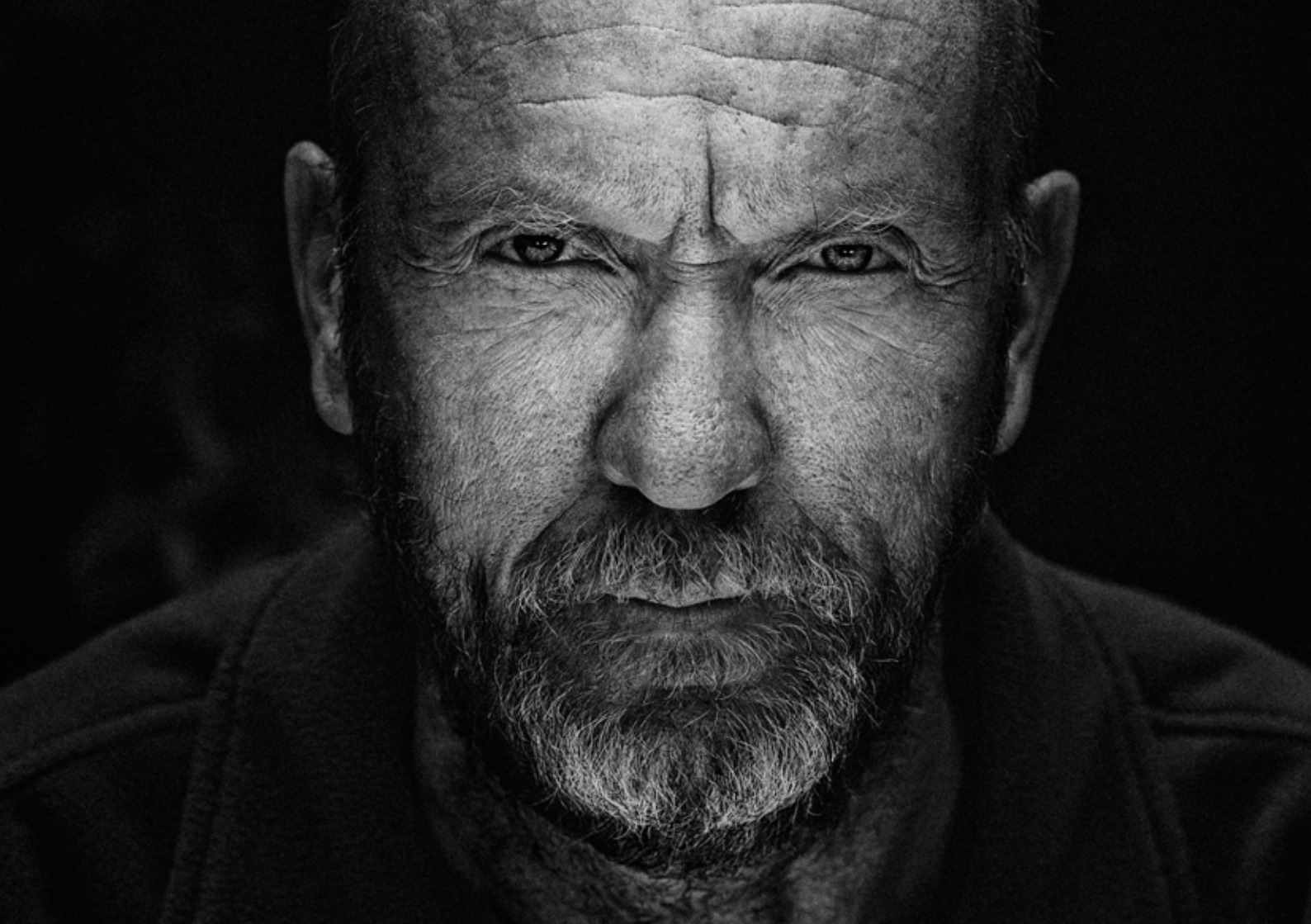

# **TAKING BALING TO NEW HEIGHTS**

## **ORKEL ROUND BALES:**

*SUPERIOR DENSITY  
HIGHER FORAGE QUALITY  
IMPROVED ANIMAL PERFORMANCE*

## **ORKEL DENS-X COMPACTOR:**

*HIGH CAPACITY  
RAPID RIG AND WRAP  
USER FRIENDLY*



DENS-X  
COMPACTOR

Orkel

# NEW, INNOVATIVE TECHNOLOGY

**MAKES THE NEW DENS-X  
COMPACTOR IDEAL FOR BALING  
TOP-QUALITY BALES.**

## **GENERATION X**

The Dens-X is the new generation of Orkel Compactors with higher capacity and smarter solutions of the feed hopper, a new brilliant control system and a unique weighing system. The innovative new feed hopper is a patent pending solution with high capacity. It enables fast unloading from trailers and has a specially designed system to move the material efficiently to the elevator.

## **BALE ANYTHING**

The Orkel Dens-X Compactor transforms bulk material such as biomass and fine particle materials into easy-to-handle high density round bales.

Our customers use Orkel Compactors to successfully handle a wide range of materials, such as:

- Maize
- Cotton
- Crimped grain
- Chopped grass
- Energy crops
- Grape marc
- Hay
- Linen waste
- Manure
- Sugar pulp
- TMR
- Wood wastes
- Saw dust

## **TAILOR MADE TO MEET YOUR NEEDS**

Orkel takes great pride in offering machines tailor made to meet every specific need. Varieties like different feed hoppers, chamber belts and mobile or stationary versions are among the many customizations we make to optimize the compactor for our customers. We facilitate the adaption to your existing production line and offer completely integrated solutions that fit seamlessly into your existing facilities, conveyor belts, safety systems etc.

**«ORKEL COMPACTORS HAVE  
BEEN AN IMPORTANT PART OF  
OUR CONTRACTOR BUSINESS  
FOR TEN YEARS. WITH THE  
NEW ORKEL DENS-X, WE WILL  
TAKE ANOTHER BIG LEAP IN  
INCREASING OUR CAPACITY»**

**FRANK VERHOEST  
BELGIUM**





**MAIZE**



**GRAPE MARC**



**TMR**



**MANURE**



**SAW DUST**



# HIGH CAPACITY FEED HOPPER

THE ORKEL DENS-X COMPACTOR INCLUDES A NEW, UNIQUE HOPPER SOLUTION WITH SUPERIOR CAPACITY. THIS PATENT PENDING SOLUTION ENABLES EASY ACCESS AND FAST UNLOADING FROM TRAILERS. THE TIPPER FLIP ENSURES MINIMUM SPILLAGE AND EASY RIGGING EVEN ON SOFT SURFACES.

«I CAN SEE THIS MACHINE IS MADE  
BY EXPERTS»

DANIËL DESMETH  
CONTRACTOR, BELGIUM

## EASY RIG AND WRAP

It takes just a few minutes to rig the compactor and start baling and wrapping. The flexible drawbar makes it quick and easy to move from transport position to baling mode. Using only the tractor hydraulics you can unfold the receiving hopper ready for loading directly from trailers. Quicker and easier than ever.

## HIGHLIGHT FEATURES

- Supreme feed hopper size and capacity
- 3,5 m wide in operational mode
- Tipper flip prevents spillage of forage and bulk material
- Full width belts for better material flow
- Flexible drawbar for quick setup

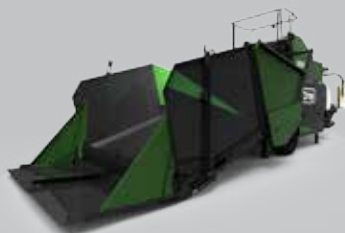

For loading



For loading



Half Folded



For transport



# HOW IT WORKS

## 1. TRANSPORT TO CHAMBER

Material is tipped from a trailer or from a front-end loader to the feed hopper. The material is moved by transport belts in full width to the elevator. A robust chained conveyor system with steel carriers loads the material into the compression chamber.

## 2. COMPRESSION

Specially designed belts inside the chamber prevent all kinds of spillage, while the design of steel rollers and high pressure chamber makes bales of the highest density.

Automatically lubricated bushings prevent dust and moisture damage and gives long lifetime.

## 3. WIDE FILM WRAPPING

After compaction the bales are wrapped in wide film or net to allow the bales to maintain their shape and density. Remote control and auto-break enable quick film roll changes.

## 4. WRAPPING

The chamber is opened and a predefined number of layers of film seals the material in a compact bale on the wrapping table. Finally the bale is rolled to the ground and can be picked up one, two or three at a time, and stacked up to 8 bales in height. 15 film rolls can be stored under the side covers.



## ORKEL DENS-X COMPACTOR - TECHNICAL DETAILS

Orkel Dens-X Compactor is operated using hydraulics, with power being supplied by either a tractor or an electric motor [Powerpack PP55].

*Required power:* >120 HP tractor  
or >55 kW electrical  
motor

*Total weight:* 9850-13000 kg,  
depending on  
specifications

*Capacity:* Up to 60 bales/hour

*Bale volume:* 1.25 m<sup>3</sup>  
[115cm x 120cm]

*Bale weight:* 300-1200 kg

*Film roll holder:* 15 rolls

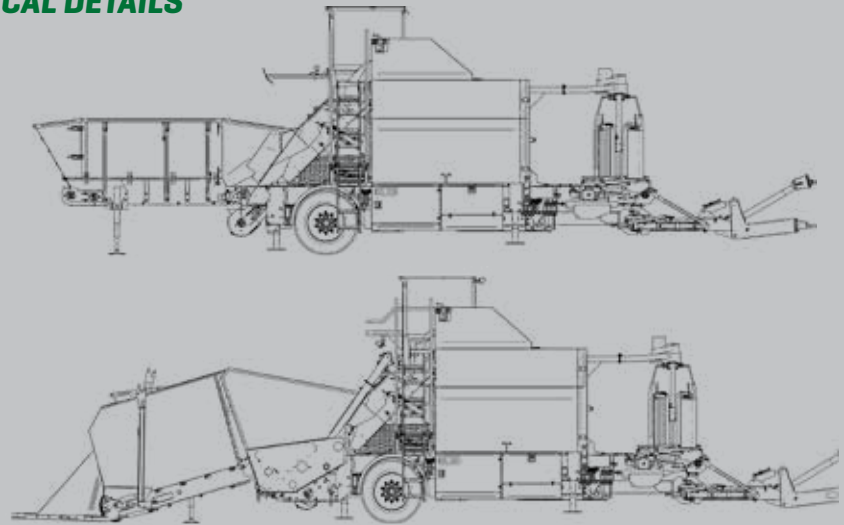

## GLOBAL 24 HOUR SUPPORT

*We know how important it is that your equipment works. Your needs for technical help, maintenance or spare parts are covered by knowledgeable and experienced technical consultants situated in all six continents and more than 40 countries.*



**DENS-X**  
COMPACTOR

# A NEW DEGREE OF USER FRIENDLINESS

*THE DENS-X CONTROL SYSTEM IS THE NEW GENERATION OF ELECTRONICS AND CONTROL UNITS. TOGETHER WITH OUR NEW ELECTRIC PROPORTIONAL VALVES IT GIVES YOU EASIER CONTROL AND HIGHER EFFICIENCY.*

## **Easy to use**

An intuitive touch screen makes it easy to understand and run the machine. The symbols and pictures overcome language barriers. Wide viewing angles and high brightness offer good readability also in direct sunlight.

## **Better control**

As the machine runs automatically you can at all times see what is going on. You may choose

to control and adjust it for your specific needs, as all functions can be controlled from the display.

## **Optimize the processes**

The machine comes with several programs as factory presets for different materials. In addition you can make your own adjustments and save them as different baling programs. E.g. you may store one set of settings for baling a wet material, and one for the material when dry.

## **Robust and reliable**

The electronics hardware is developed for heavy industries like mining and forestry, and is reliable in any condition. The tight aluminium housing of the screen is waterproof, totally dust tight and it endures cold, heat, vibration, moisture and impacts.



# «HIGH DENSITY BALING IS WIN-WIN»

DENIS JOHNSON, JT JOHNSON & SONS , AUSTRALIA

## BALING - FOR EASIER TRANSPORT AND STORAGE

**BALING IS A CLEAN AND EFFICIENT WAY TO HANDLE BULK MATERIAL. THE DENS-X ENABLES THE MATERIALS TO BE COMPACTED INTO STABLE AND HOMOGENOUS UNIT PACKAGES.**

### **EFFECTIVE COMPACTION**

The volume of most bulk materials can be reduced down to one third of their original volume. Even materials with high dry matter content can easily be compacted. The Orkel bale size is optimized for loading of bales into trailers, containers [44 units in 40ft container], ships or similar.

### **PRESERVING OUTSTANDING QUALITY**

The Orkel Compactors probably makes the bales with the highest density in the market. The result is superior conservation of the content. This is due to the oxygen being pressed out of the material during the compaction process. Together with the tight wrapping the result is that virtually no oxygen being left in the material and no oxygen gets in.

### **IMPROVING SILAGE QUALITY**

Benefits are less bacterial spoilage during storage and transportation, and stable silage for longer term storage. On top of that, our high density bales have lower rates of air infiltration during feedout.

### **THE KEY TO SUCCESS = HIGH DENSITY BALES**

Minimal or no losses in forage conservation provides huge benefits to the livestock farmer. User experience during more than 10 years as well as several independent test reports confirm the advantages of Orkel bales to provide:

- Increased milk yield/ live weight gain
- Higher DM intake
- Better milk quality by increased protein and fat
- Improved animal health

In turn, these benefits have a positive impact on the financial return from milk and meat production.

## «THE ORKEL MACHINES HAVE BEEN A SAFE AND PROFITABLE INVESTMENT»

HENRY DU VAL DE BEAULIEU  
YELSPA LTD, UK





*What began as a modest production of small toys and tricycles for local customers, has now become a global supplier of high quality machinery.*



# NORWEGIAN CRAFTSMANSHIP SINCE 1949

In 1949, at the age of 27, the Norwegian welder Johan Gjønnnes invested in a welding machine. The intention was to make a living out of repairing sledges and bicycles for neighbours and acquaintances. In a small smokehouse in Fannrem, around 45 kilometers southwest of Trondheim, he gradually developed the business into production of toys, tricycles and simple hand carriages for agriculture.

## **INNOVATIVE PRODUCTS BASED ON EXPERIENCE**

In the 60s and 70s, the production of agriculture oriented equipment increased, and as the wheels turned faster, more

employees got involved in the production. Since most of the workers came from farms or had their background in farming, the development of new products were based on broad practical experience and a flair for the users needs.

## **FROM COUNTRYSIDE WORKSHOP TO GLOBAL BRAND**

Soon, Orkel became an established brand, known for its reliable quality. In 1986 the first Orkel baler was invented, and with the round grass bales, Orkel really got the worlds attention. Today Orkel Group is an established, strong and pioneering supplier of round balers, Compactors and

transport equipment represented in over 50 countries on all continents.

The company is one of the biggest manufacturers in its segment in Norway and has a unique position on the domestic market. It has earned critical acclaim and a reputation for high quality through experience and innovative design.

The Orkel of today is quite a long way from the small, modest countryside workshop the founder Johan Gjønnnes established over 60 years ago. Quality, innovation, commitment and passion for excellent craftsmanship are still ideals we work towards.



Developing profitable customers

## CONTACT

### Sale Office Factory

Johan Gjønnnes' veg 25  
7320 Fannrem  
NORWAY

### Administration:

+47 72 48 80 00

### Technical Support:

+47 918 43 553

[orkel.com](http://orkel.com)

**YOUR LOCAL SALES CONTACT:**



From: Ole Ekestrand Øien, Daniel Klov/Poplin, Ole Håvard Aagaard Ørien

